

# REAMERS





**GUHRING**











# High speed steel reamers

Tool illustration				Tool material	Guhring no.
Standard	Form	Surface	Cutting direction	Diameter range	

## NC machine reamers

				HSS-E	455
Guhring std.		○	rh	1,000 - 12,030	
				HSS-E	490
Guhring std.		○	rh	1,500 - 20,000	

## Machine reamers

				HSS-E	404
DIN 208	A	○	rh	3,000 - 50,000	
				HSS-E	405
DIN 208	B	○	rh	3,000 - 50,000	
				HSS-E	642
DIN 208	B	Ⓢ	rh	8,000 - 20,000	
				HSS-E	401
DIN 212	A	○	rh	1,000 - 5,500	
				HSS-E	402
DIN 212	B	○	rh	1,000 - 3,700	
				HSS-E	440
DIN 212	C	○	rh	4,000 - 20,000	
				HSS-E	468
DIN 212	D	○	rh	3,800 - 20,000	
				HSS-E	641
DIN 212	D	Ⓢ	rh	4,000 - 20,000	
				HSS-E	457
DIN 212	A	○	lh	1,000 - 6,000	
				HSS-E	467
DIN 212	C	○	lh	4,500 - 10,000	
				HSS-E	496
DIN 212	B/D	○	rh	0,950 - 12,050	





○ bright	● steam tempered	● nitrided lands	● nitrided	● golden brown	● TiAlN
● A TiAlN	● C TiCN	● F FIRE	● P AlCrN	● S TiN	● M MolyGlide

Tool illustration				Tool material	Guhring no.
Standard	Form	Surface	Cutting direction	Diameter range	



## Machine reamers with coolant duct

				HSS-E	1431
DIN 212	C	○	rh	5,000 - 20,000	

## Machine reamers

				HSS-E	488
DIN 8089	A	○	rh	4,000 - 20,000	
				HSS-E	489
DIN 8089	B	○	rh	4,000 - 20,000	
				HSS-E	497
Set Guhring no. 458					
DIN 8089	B	○	rh	3,760 - 12,050	
				HSS-E	1432
DIN 8089	A	○	rh	5,000 - 20,000	

## Quick spiral reamers

				HSS-E	403
DIN 212		○	rh	1,000 - 5,500	
				HSS-E	469
DIN 212	E	○	rh	4,000 - 20,000	
				HSS-E	406
DIN 208	C	○	rh	3,000 - 32,000	

## Machine bridge reamers

				HSS	414
DIN 311		●	rh	6,400 - 40,000	



## Expanding machine reamers

				HSS-E	430
Guhring std.		○	rh	8,000 - 32,000	

## High speed steel reamers

Tool illustration				Tool material	Guhring no.
Standard	Form	Surface	Cutting direction	Diameter range	



### Machine bottoming reamers

				HSS-E	419
Guhring std.		○	rh	2,500 - 12,000	
				HSS-E	420
Guhring std.		○	rh	3,000 - 32,000	



### Stepped machine reamers

				HSS-E	431
Guhring std.		○	rh	5,000 - 38,000	

### Shell reamers

				HSS-E	409
DIN 219	C	●	rh	25,000 - 98,000	
				HSS-E	407
DIN 219	A	●	rh	26,000 - 98,000	
				HSS-E	408
DIN 219	B	●	rh	25,000 - 75,000	



### Carbide high performance reamers HR 500

				Solid carbide	1685
Guhring std.	<b>A</b>		rh	4,000 - 20,000	
				Solid carbide	1686
Guhring std.	<b>A</b>		rh	4,000 - 20,000	
				Solid carbide	1675
Guhring std.	<b>A</b>		rh	3,970 - 12,030	
				Solid carbide	1676
Guhring std.	<b>A</b>		rh	3,970 - 12,030	
				Carbide	1680
Guhring std.	<b>A</b>		rh	22,000 - 40,000	

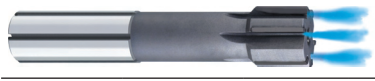

## Carbide reamers

Tool illustration				Tool material	Guhring no.
Standard	Form	Surface	Cutting direction	Diameter range	







### Carbide high performance reamers HR 500

				Carbide	1681
Guhring std.	<b>A</b>		rh	22,000 - 40,000	
				Carbide	1682
Guhring std.	<b>A</b>		rh	22,000 - 40,000	
				Carbide	1683
Guhring std.	<b>A</b>		rh	22,000 - 40,000	

### NC machine reamers

				Solid carbide	1427
Guhring std.		○	rh	0,980 - 12,050	
				Solid carbide	1449
Guhring std.		○	rh	3,000 - 12,000	

### Machine reamers



				Carbide	717
~ DIN 8050	A	○	rh	5,000 - 20,000	
				Carbide	718
~ DIN 8050	B	○	rh	5,000 - 20,000	
				Carbide	1408
~ DIN 8093	A	○	rh	1,000 - 20,000	
				Carbide	1428
~ DIN 8093	A	<b>A</b>	rh	2,000 - 20,000	
				Carbide	1409
~ DIN 8093	B	○	rh	1,000 - 20,000	
				Carbide	1429
~ DIN 8093	B	<b>A</b>	rh	2,000 - 20,000	
				Carbide	719
~ DIN 8051	A	○	rh	5,000 - 40,000	

○ bright	● steam tempered	◐ nitrided lands	● nitrided	● golden brown	<b>A</b> TiAlN
<b>A</b> AlTiN	<b>C</b> TiCN	<b>F</b> FIRE	<b>P</b> AlCrN	<b>S</b> TiN	<b>M</b> MolyGlide





## Carbide reamers

Tool illustration				Tool material	Guhring no.
Standard	Form	Surface	Cutting direction	Diameter range	



### Machine reamers

				Carbide	720
~ DIN 8051	B	○	rh	6,000 - 32,000	
				Carbide	1410
~ DIN 8094	A	○	rh	5,000 - 40,000	
				Carbide	1411
~ DIN 8094	B	○	rh	5,000 - 40,000	

### Machine reamers

				Carbide	674
~ DIN 8090	A	○	rh	4,000 - 15,000	
				Carbide	1430
~ DIN 8090	A	ⓐ	rh	3,000 - 14,000	
				Carbide	1407
~ DIN 8090	B	○	rh	3,000 - 16,000	
				Carbide	737
~ DIN 8090	C	○	rh	4,000 - 15,500	

### Expanding machine reamers

				Carbide	749
Guhring std.		○	rh	8,000 - 20,000	
				Carbide	740
Guhring std.		○	rh	8,000 - 40,000	



### Stepped machine reamers

				Carbide	743
Guhring std.		○	rh	7,000 - 38,000	



## Taper reamers/Hand reamers

Tool illustration				Tool material	Guhring no.
Standard	Form	Surface	Cutting direction	Diameter range	



### Hand taper reamers

				HSS	428
DIN 9	A	○	rh	1,000 - 50,000	
				HSS	429
DIN 9	B	○	rh	1,500 - 50,000	
				HSS	1433
Guhring std.		○	rh	3,000 - 23,000	



### Machine taper reamers

				HSS-E	410
DIN 2179		○	rh	1,000 - 12,000	
				HSS-E	411
DIN 2180		○	rh	5,000 - 50,000	

### Hand reamers

				HSS	412
DIN 206	A	○	rh	1,000 - 60,000	
				HSS	413
DIN 206	B	○	rh	1,000 - 60,000	

### Hand reamers

	adjustable			HSS	415
DIN 859	B	○	rh	4,000 - 60,000	
	expanding			HSS	416
Guhring std.		○	rh	6,400 - 80,000	

### Shell reamers

				Carbide	727
DIN 8054		○	rh	25,000 - 55,000	

○ bright	● steam tempered	● nitrided lands	● nitrided	● golden brown	ⓐ TiAlN
ⓐ AlTiN	● C TiCN	● F FIRE	● P AlCrN	● S TiN	● M MolyGlide

# COUNTERSINKS











**GUHRING**















# HSS, HSS-E and carbide countersinks

Tool illustration				Tool material	Guhring no.
Standard	Form	Surface	Cutting direction	Diameter range	



## 60° countersinks

	HSS	470	
DIN 334	A	 rh	8.000 - 20.000
	HSS	472	
DIN 334	C	 rh	6.300 - 25.000
	HSS	471	
DIN 334	B	 rh	16.000 - 100.000
	HSS	473	
DIN 334	D	 rh	16.000 - 80.000

## 90° countersinks



	HSS	474	
DIN 335	A	 rh	8.000 - 20.000
	HSS	476	
DIN 335	C	 rh	4.300 - 31.000
	HSS	1326	
DIN 335	C	 rh	4.300 - 31.000
	HSS	327	
DIN 335	C	 rh	5.000 - 31.000
	HSS	477	
DIN 335	D	 rh	15.000 - 100.000
	HSS	328	
DIN 335	D	 rh	25.000 - 50.000
	HSS	475	
DIN 335	B	 rh	16.000 - 100.000

## 90° countersinks for fine tolerances





	HSS	436
DIN 1866	 rh	2.000 - 19.000

Tool illustration				Tool material	Guhring no.
Standard	Form	Surface	Cutting direction	Diameter range	





## 90° countersinks for fine tolerances

	HSS	1318
DIN 1866	 rh	5.000 - 19.000





## 90° countersinks for medial tolerances

	HSS	437
DIN 1866	 rh	6.600 - 21.500
	HSS	1319
DIN 1866	 rh	6.600 - 21.500





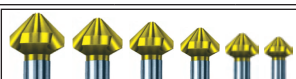

## 90° countersinks for tapping size holes

	HSS	438
DIN 1866	 rh	6.000 - 19.000
	HSS	1323
DIN 1866	 rh	6.000 - 15.000

## 90° countersinks

	HSS	498	
DIN 335	C	 rh	7.000 - 7.000
	HSS	499	
DIN 335	C	 rh	7.000 - 7.000

## 120° countersinks



	HSS	478	
DIN 347	A	 rh	8.000 - 20.000
	HSS	480	
Guhring std.	 rh	16.000 - 16.000	
	HSS	481	
Guhring std.	 rh	25.000 - 40.000	

 bright	 steam tempered	 nitrided lands	 nitrided	 golden brown	 TiAlN
 TiAlN	 TiCN	 FIRE	 AlCrN	 TiN	 MolyGlide

# HSS, HSS-E and carbide countersinks

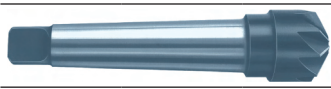

Tool illustration				Tool material	Gühring no.
Standard	Form	Surface	Cutting direction	Diameter range	



## 120° countersinks

				HSS	479
DIN 347	B		rh	20.000 - 100.000	



## Counterbores with fixed pilots for fine tolerances



				HSS	482
DIN 373			rh	2.200 - 20.000	

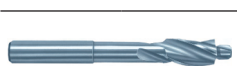

			rh	HSS	324
DIN 373			rh	6.000 - 20.000	

			rh	HSS	485
Gühring std.			rh	18.000 - 40.000	

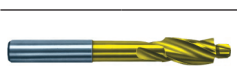
## Counterbores with fixed pilots for medial tolerances



				HSS	483
DIN 373			rh	6.000 - 20.000	

			rh	HSS	325
DIN 373			rh	6.000 - 18.000	

			rh	HSS	486
Gühring std.			rh	18.000 - 40.000	

## Counterbores with fixed pilots for tapping size holes

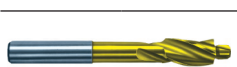

				HSS	484
DIN 373			rh	6.000 - 20.000	

			rh	HSS	326
DIN 373			rh	6.000 - 18.000	

			rh	HSS	487
Gühring std.			rh	18.000 - 33.000	

Tool illustration				Tool material	Gühring no.
Standard	Form	Surface	Cutting direction	Diameter range	



## Counterbores with hole for detachable pilot



				HSS	463
DIN 375			rh	15.000 - 63.000	

## Spot facers

				HSS-E	432
DIN 1862			rh	3.500 - 13.000	

			rh	HSS-E	433
DIN 1862			rh	6.000 - 30.000	

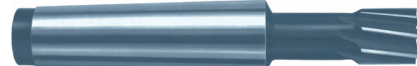
			rh	HSS-E	434
DIN 1862			rh	10.000 - 30.000	



			rh	HSS-E	435
DIN 1862			rh	20.000 - 48.000	



## Back spotfacers













				Carbide	1640
Gühring std.			rh	44.000 - 115.000	

				HSS	1638
Gühring std.			rh	11.000 - 115.000	

## De-burring forks

				Solid carbide	4101
Gühring std.			rh	2.000 - 8.000	

				Solid carbide	4100
Gühring std.			rh	2.000 - 8.000	

 bright   
  steam tempered   
  nitrided lands   
  nitrided   
  golden brown   
  TiAlN  
 AlTiN   
  TiCN   
  FIRE   
  AlCrN   
  TiN   
  MolyGlide

## SL reamers

Guhning std.					Carb.-UF		0.98 ... 12.05	5527	75
-----------------	--	--	--	---	----------	---	----------------	------	----